



# Precision Spectroscopy of HD at $1.4 \mu\text{m}$

Eugenio Fasci, Antonio Castrillo, Hemanth Dinesan, **Stefania Gravina**, Luigi Moretti  
and Livio Gianfrani

Department of Mathematics and Physics  
Molecules and Precision Measurements (MPM) Group  
Università della Campania “Luigi Vanvitelli”, Caserta, Italy

# Outlines

- ❑ Scientific motivations;
- ❑ Cavity ring-down spectroscopy (CRDS):
  - ❑ A brief introduction;
  - ❑ Frequency-stabilized CRDS (FS-CRDS);
- ❑ Our FS-CRDS experimental set-up;
- ❑ Absolute frequency measurement procedure;
- ❑ Results and discussion;
- ❑ Summary and Outlooks.

# The HD molecule

- Two nuclei and two electrons;
- Weak infrared spectrum, which originates from the existence of a small electric dipole moment due to the inversion symmetry breaking in conjunction to the breakdown of the Born-Oppenheimer approximation.

$$D_{el} \sim 10^{-5} D$$

$$S_{\max} \sim 10^{-25} \text{ cm/molecule}$$

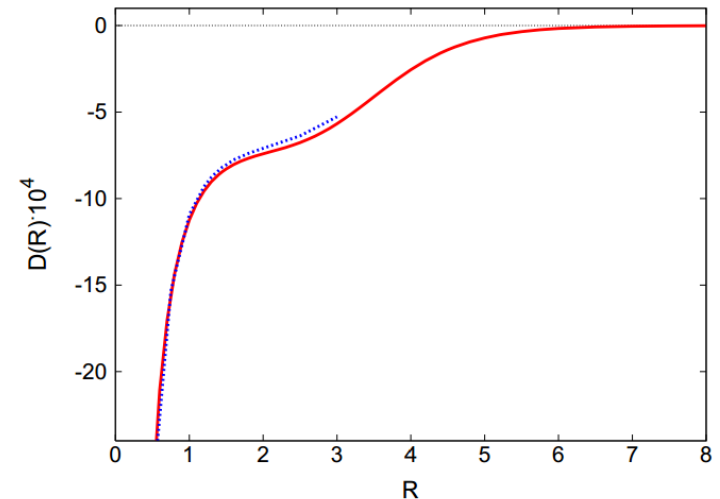

K. Pachucki, J. Komasa, *J. Chem. Phys.*, 129, 034102, 2008.

## Why?

### Astrophysical and Planetary applications:

- Indicator of the baryonic matter density in the Early Universe;
- Investigation of exoplanetary and cool star atmospheres.

### Interest in the Fundamental Physics:

- Misure of the possible variation in the proton/electron mass ratio on cosmological time scale;
- A benchmark system which can put constraints on a fifth force at the Angstrom scale.

# State of the art

## Ab-initio quantum-mechanical calculations of energy dipole transition levels and moments:

K. Pachucki, J. Komasa, Phys. Chem. Chem. Phys., 12 (2010) pp 9188-9196.

## Experimental investigations:

- R. A. Durie, G. Herzberg, Can J. Phys., 38 (1960) pp 806-818;
- S. Kassi, A. Campargue, J. Mol. Spectrosc., 267 (2011) pp 36-42;
- L-G. Tao, et al. Phys. Rev. Lett., 120 (2018) 153001;
- F. M. J. Cozijn, et al. Phys. Rev. Lett., 120 (2018) 153002;

Line center frequency measurements with an uncertainty of 30 MHz

Discrepancy of 900 kHz

**Our target**

**HIGH ACCURATE MEASUREMENT** of HD electric-dipole first overtone band transition R(1) line-center frequency in the Doppler broadened regime, using a **HIGH SENSITIVITY SPECTROMETER** (a pair of phase-locked extended-cavity diode lasers referenced to an Optical Frequency Comb Synthesizer).

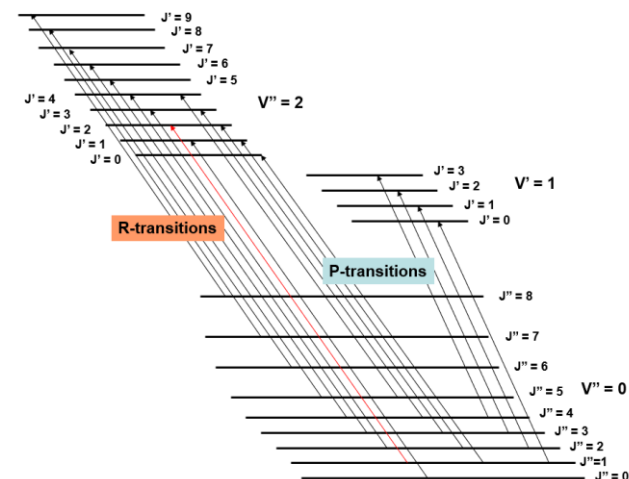

# Cavity Ring-Down Spectroscopy

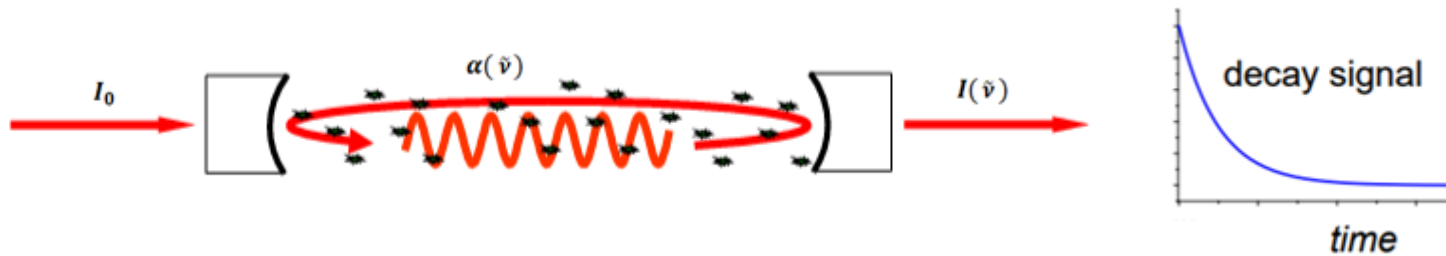

## Cavity ring-down times:

Empty cavity

$$\tau_0 = \frac{L}{c(1-R)}$$

Cavity filled with absorbing gas

$$\tau = \frac{L}{c(1-R + \alpha L)}$$

## Absorption coefficient

$$\alpha(\nu) = N\sigma(\nu) = \frac{1}{c} \left( \frac{1}{\tau_0} - \frac{1}{\tau(\nu)} \right)$$

Decay rate reflects:

- Loss due to mirrors;
- Absorption of gas between mirrors.

## CRDS benefits:

- relatively low detection limits (below  $10^{-10} \text{ cm}^{-1}$ );
- compact sample volumes (ring-down cells generally occupy  $< 1 \text{ m}$  in length);
- very long path-lengths (up to 50 km);
- immune from laser intensity fluctuations (in principle);
- potentially high spectral resolution.

## CRDS limitations:

- sensitive to mechanical vibrations, temperature variations, etc;
- cavity losses vary with optical alignment;
- polarization dependent losses;
- non-linearities in frequency detuning.

# Frequency-stabilized CRDS

Refinement of conventional single-mode CRDS in which the optical cavity is frequency stabilized to an external reference.

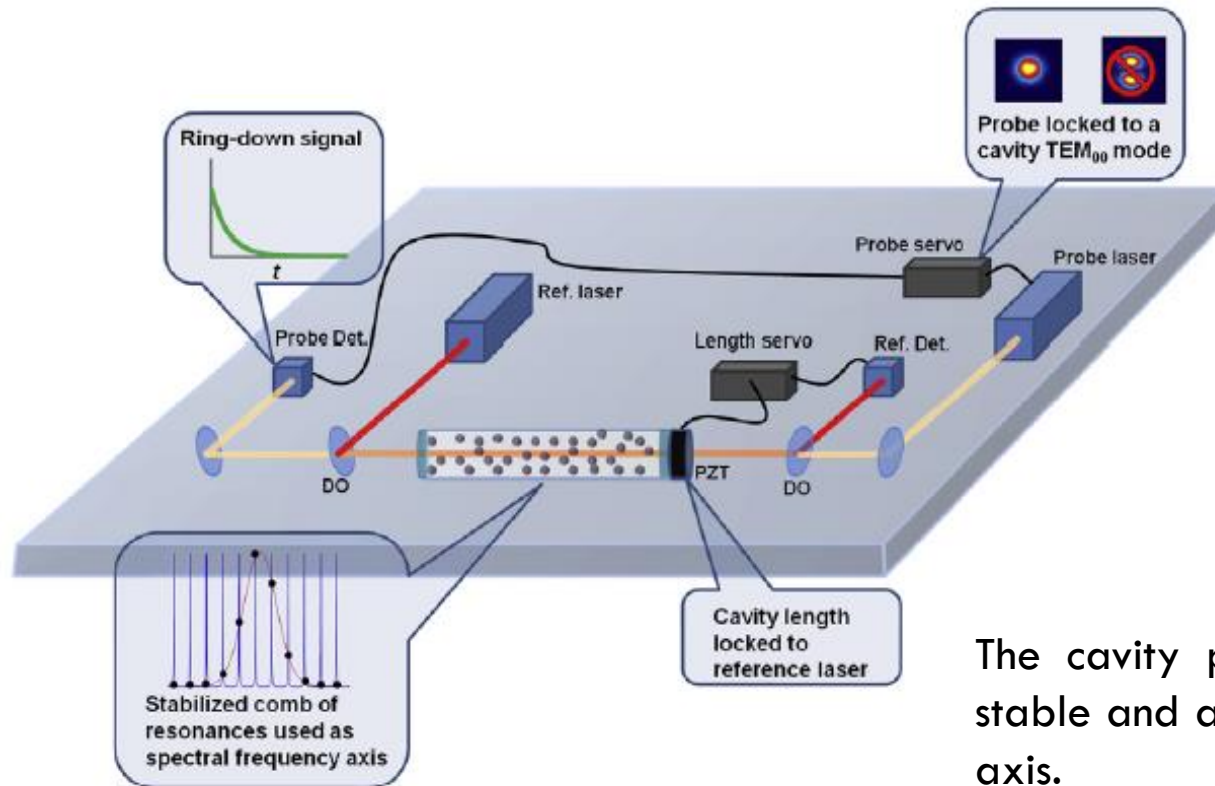

The cavity provides a linear, stable and accurate frequency axis.

Frequency resolution limited by the stability of reference laser, which was less than about 0.5 MHz.  
*J.T. Hodges et al. Rev. Sci. Instrum. 75 (2004), pp 849-863.*

# Experimental set-up: a new approach to FS-CRDS

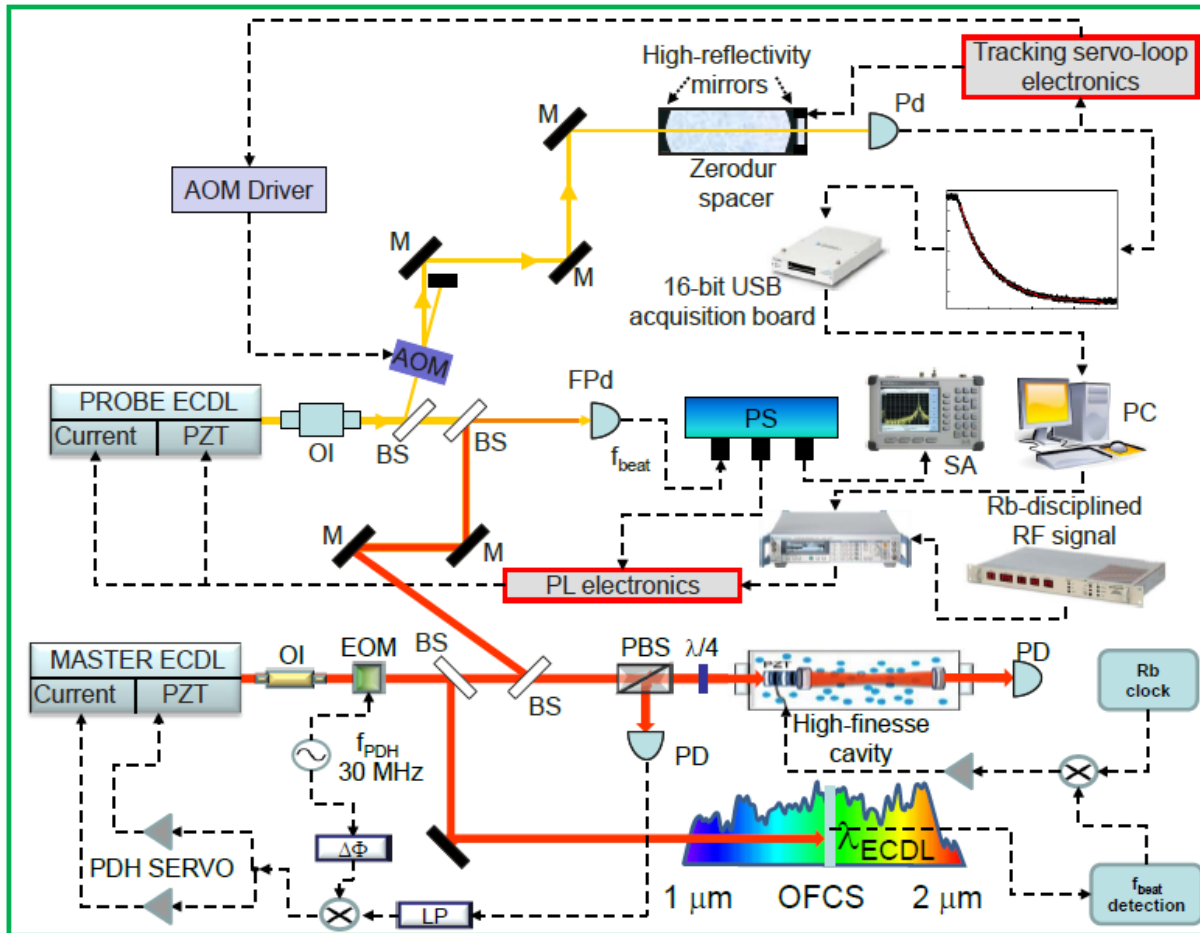

- **Master laser (ML)**, tightly locked to a high-finesse cavity by means of PDH; in turn the optical cavity is locked to OFCS;
- **Probe laser (PL)**, phase-locked to the ML;
- **Frequency control unit** (PL frequency respect to the ML);
- **Ring-down optical cavity**;
- **Tracking servo-loop** (high temporal resolution in ring-down acquisitions).

# The Master Laser



## Relative frequency stability

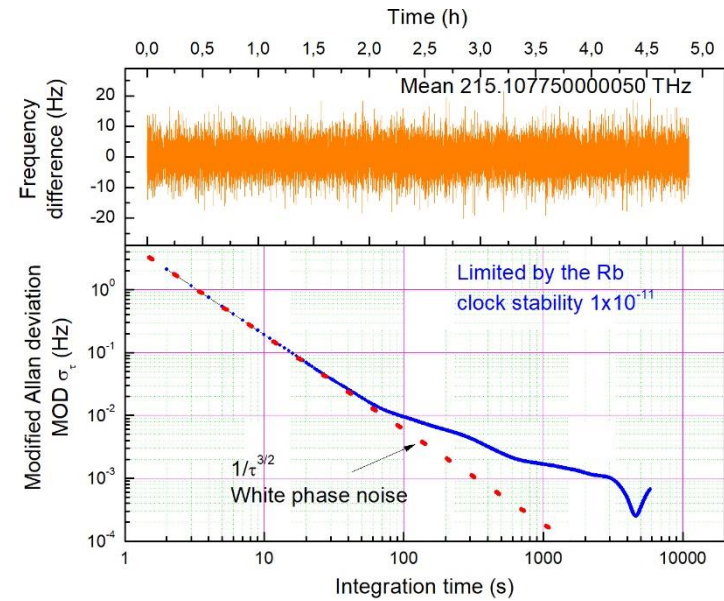
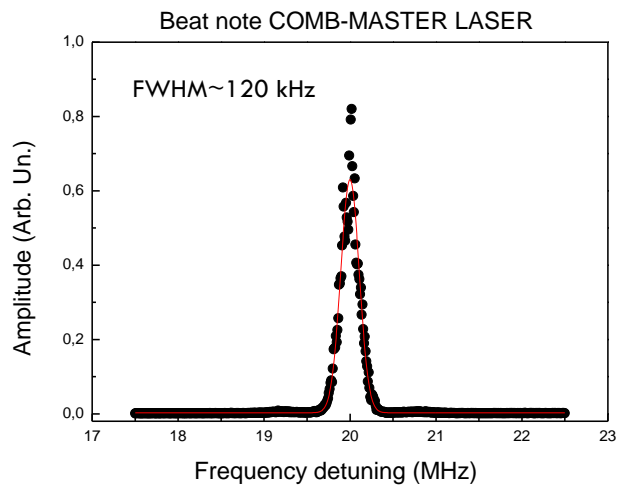

# The Probe Laser



The beat note is compared with an external variable oscillator in order to force the PL to maintain a precise frequency offset from the ML, thus resulting in a linear, high-reproducible and absolute frequency scale (at the level of  $10^{-11}$ ).

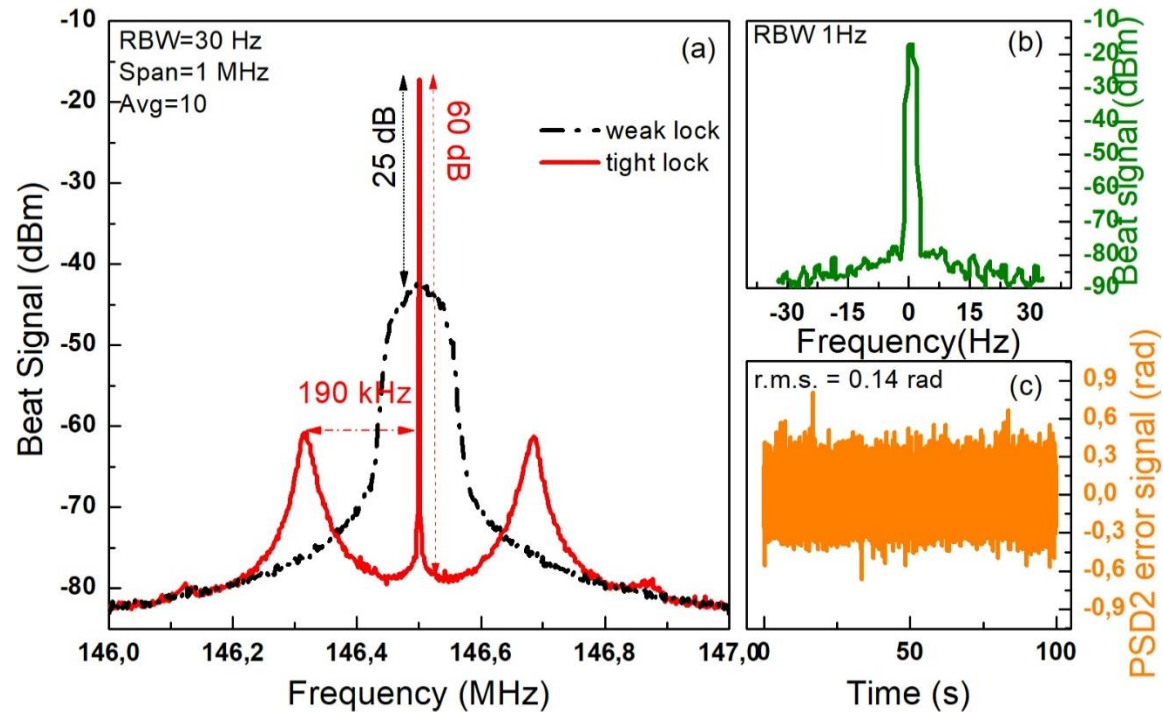
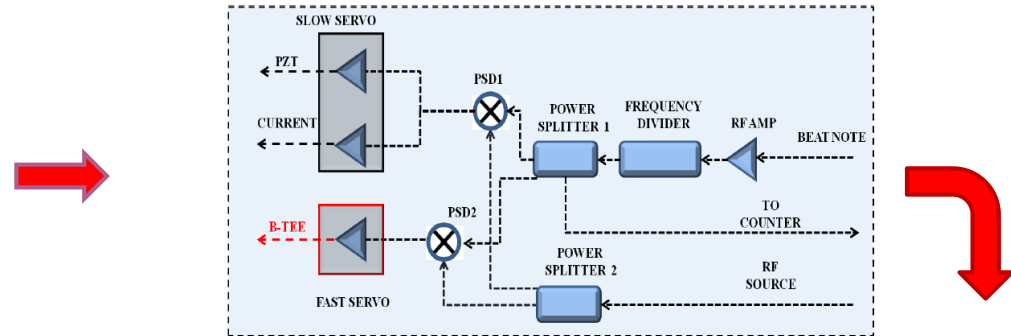

# The high-finesse optical cavity

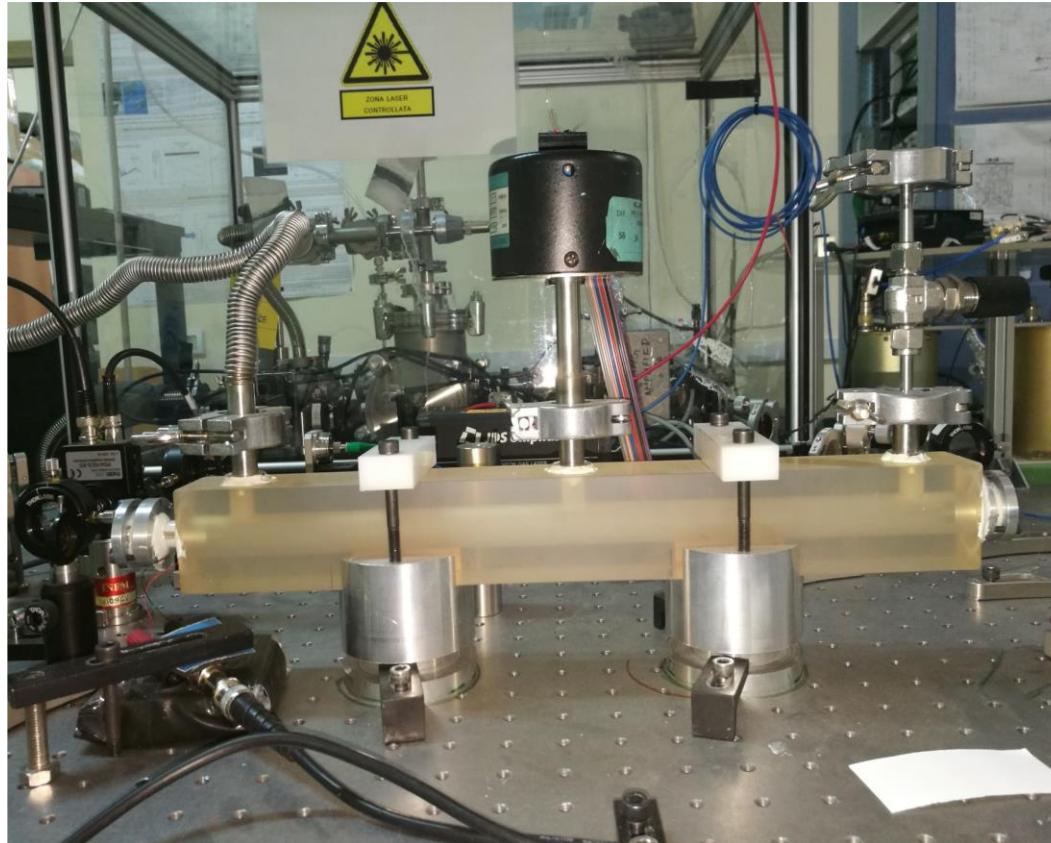

**Spacer material: ZERODUR (CTE=0.1 ppm/K);**  
**Total length (spacer+piezo): 43 cm;**  
**Radius of curvature: 100 cm;**  
**Reflectivity ~ 99.9976%.**

# The high-finesse optical cavity

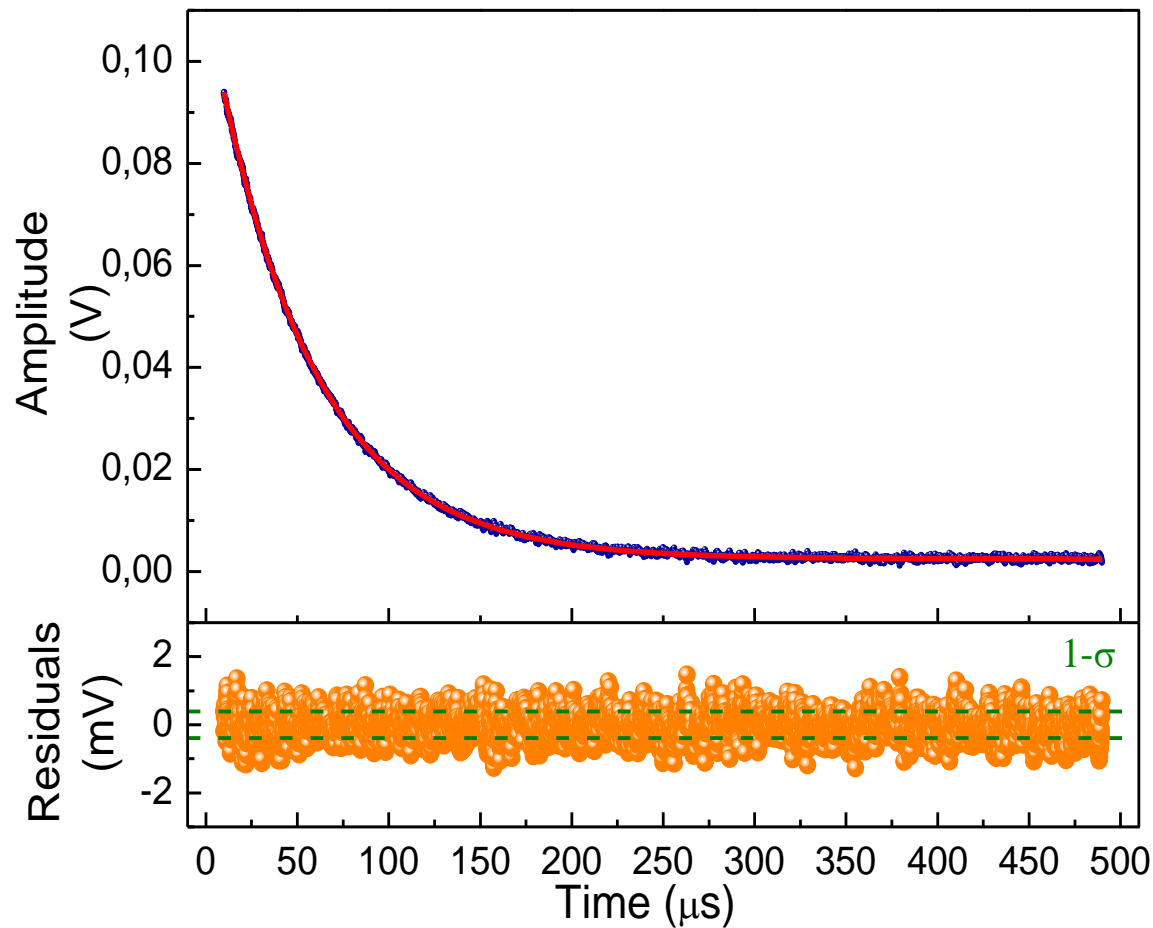

**Finesse  $\sim 160000$ ;**

**FSR  $\sim 348.5$  MHz;**

**$\tau_{\text{empty}} \sim 75 \mu\text{s}$  ;  $\Delta\nu_{\text{cav}} \sim 2$  kHz**

**$L_{\text{eq}} \sim 45$  km**

**Signal acquired with a 16-bit  
ADC, having a sample rate of  
10 MS/s**

# The tracking servo loop

The tracking servo loop electronics consists of

- Microcontroller unit;
- Ramp generator;
- Threshold detector.

The cavity moves back and forth in a narrow range around the resonance.

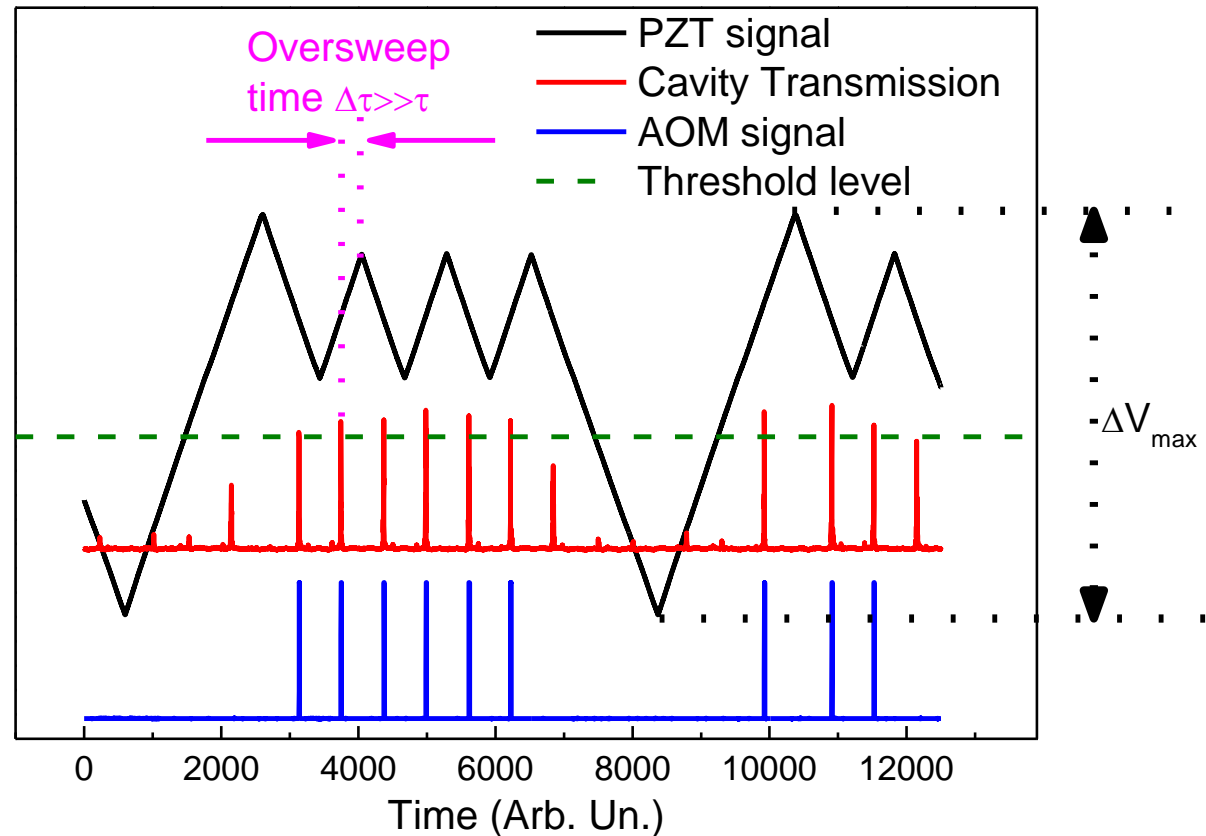

Seminal idea from O. Votava et al. *Rev. Sci. Instrum.* 83 (2012), 043110.

# Line shape measurements

Doppler-broadened spectra of the R(1) line in the 2-0 band of HD

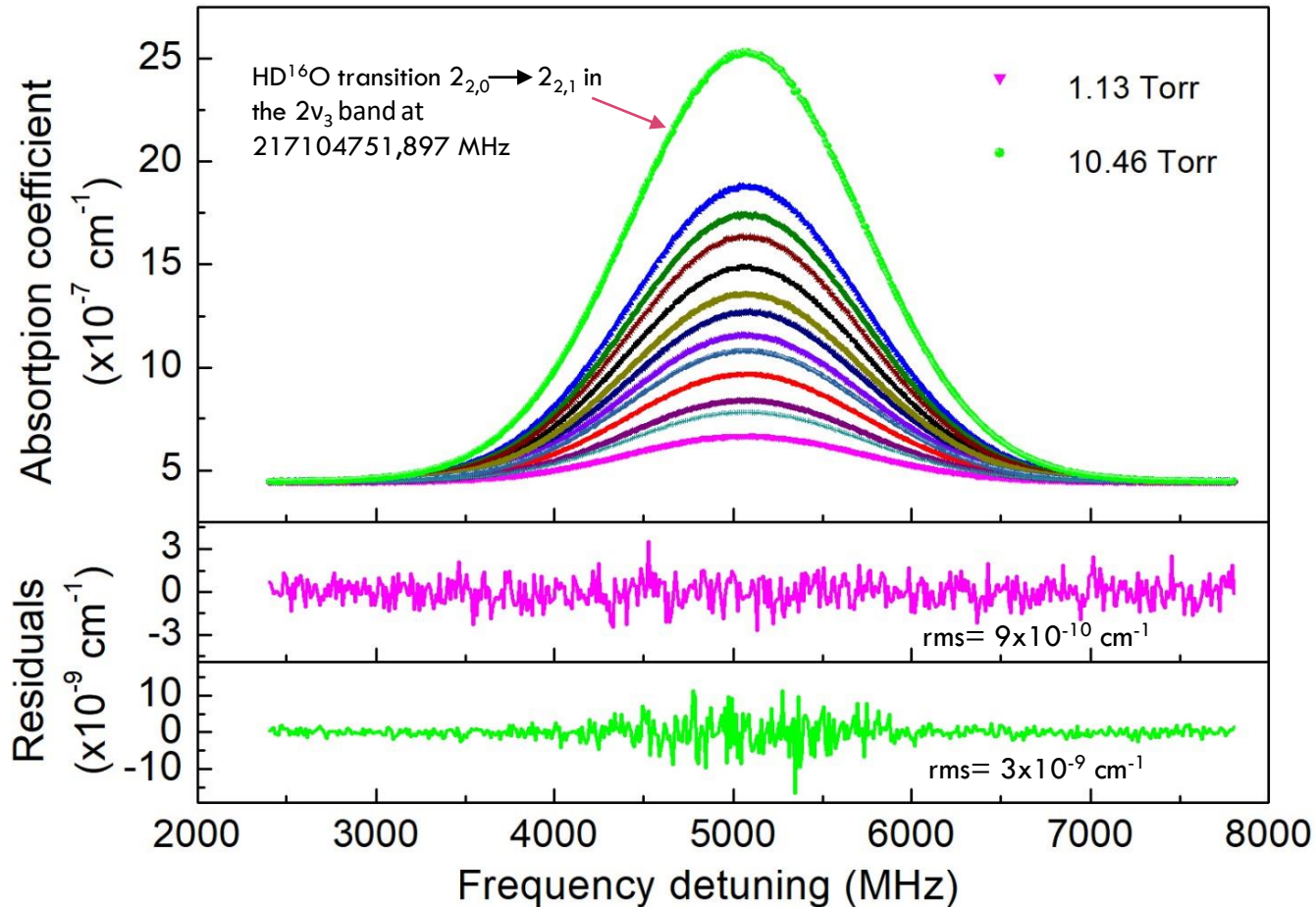

- We recorded HD spectra from a 97% <sup>2</sup>H-enriched hydrogen sample (Chemical Purity 98%) at different pressures.
- We used a Global Fitting Analysis to reduce the statistical correlation between free parameters to retrieve the line-center frequency.

# The line-shape model

$$\alpha(\nu) = (P_0 + P_1 \nu) \{ A^{HD} g^{HD} (\nu - \nu_0^{HD}) + A^{HDO} g^{HDO} (\nu - \nu_0^{HDO}) \}$$

Voigt Profile

## Asymmetric Partially-Correlated quadratic-Speed-Dependent Hard-Collision (pCqSDHC) isolated line profile (Hartmann-Tran profile)

$$\Gamma(\nu) - i\Delta(\nu) = (\Gamma_0 - i\Delta_0) + (\Gamma_2 - i\Delta_2) \left[ \left( \frac{\nu}{\tilde{\nu}} \right)^2 - \frac{3}{2} \right],$$

$$g^{pCqSDHC}(\omega) = \frac{1}{\pi} \operatorname{Re} \left\{ \frac{A(\omega)}{1 - \left[ v_{VC} - \eta \left( C_0 - \frac{3C_2}{2} \right) \right] A(\omega) + \left( \frac{\eta C_2}{\tilde{\nu}^2} \right) B(\omega)} \right\},$$

$$A(\omega) = \int \frac{f_{MB}(\vec{\nu})}{i(\omega - \omega_0 - \vec{k} \cdot \vec{\nu}) + (1 - \eta) \left\{ C_0 + C_2 \left[ \left( \frac{\nu}{\tilde{\nu}} \right)^2 - 3/2 \right] + v_{VC} \right\}} d\vec{\nu},$$

$$C_0 = \Gamma_0 - i\Delta_0,$$

$$C_2 = \Gamma_2 - i\Delta_2.$$

$$B(\omega) = \int \frac{v^2 f_{MB}(\vec{\nu})}{i(\omega - \omega_0 - \vec{k} \cdot \vec{\nu}) + (1 - \eta) \left\{ C_0 + C_2 \left[ \left( \frac{\nu}{\tilde{\nu}} \right)^2 - 3/2 \right] + v_{VC} \right\}} d\vec{\nu},$$

$$f_{MB}(\vec{\nu}) = (\sqrt{\pi} \tilde{\nu})^{-3} e^{[-(\|\vec{\nu}\|/\tilde{\nu})^2]}.$$

Model parameters	Constraints in the global analysis
$P_0, P_1, A^{HD}, A^{HDO}$	Free
$\Gamma_D^{HD}, \Gamma_D^{HDO}$	Fixed at the value corresponding to the measured temperature
$\nu_0^{HDO}$	Fixed at our determination using NICE-OHMS technique
$\nu_0^{HD}, \Gamma_0^{HD}, \Delta_0^{HD}, \Gamma_2^{HD}, \Delta_2^{HD}, \nu_{VC}^{HD}, \eta^{HD}, \Gamma_0^{HDO}$	Shared across spectra in the whole pressure range

# Long-term repeatability

Weighted mean 217105181.581(94) MHz

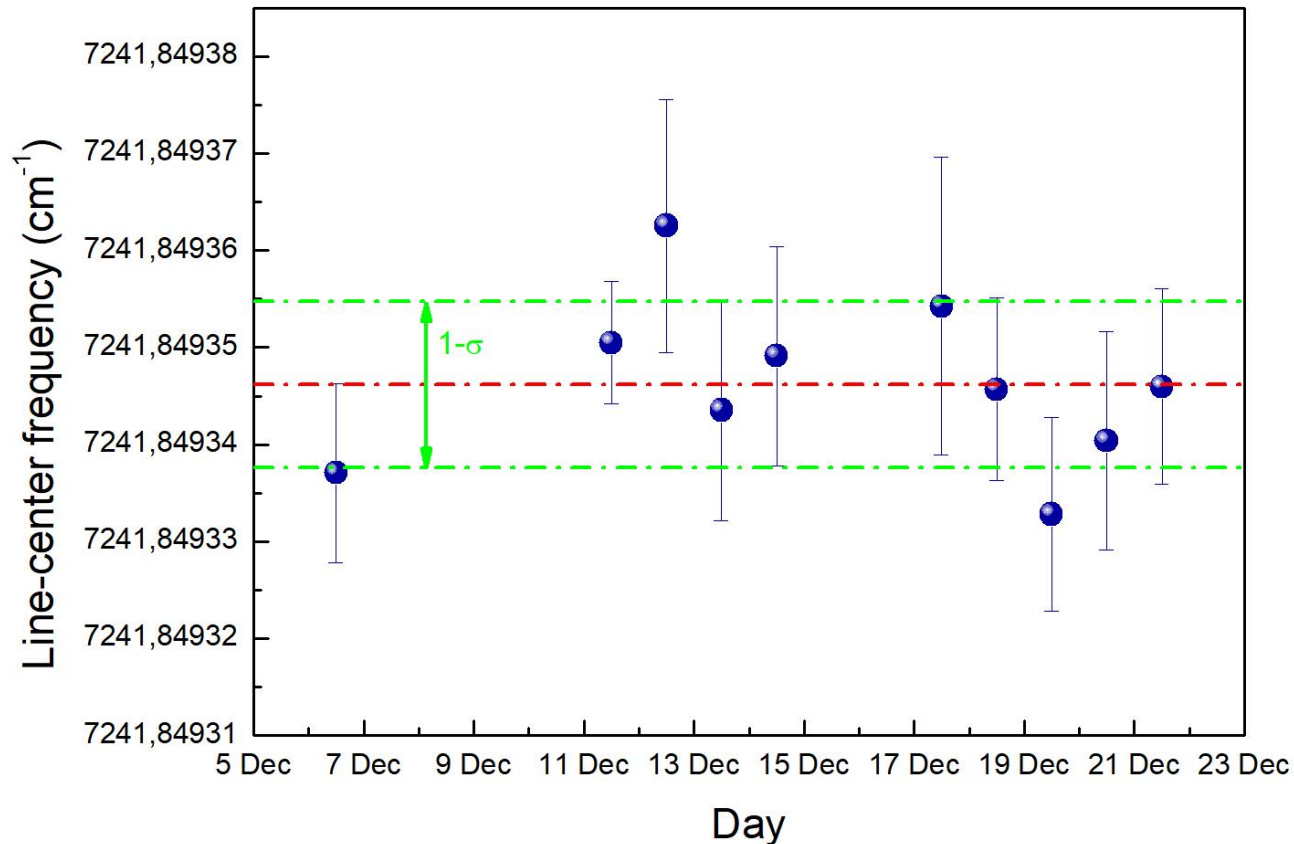

Main limitations:

- sample-handling effects
- lock-to-lock repeatability

Relative uncertainty =  $4 \times 10^{-10}$

# Retrieval of spectroscopic parameters

Parameter	Measured value	Uncertainty	Relative uncertainty
→ Line-center frequency (MHz)	217105181,581	0,094	$4,3 \times 10^{-10}$
$\gamma_0$ (kHz/Pa)	9,76	0,17	1,74
$\delta_0$ (kHz/Pa)	-0,44	0,07	15,91
$\beta_{VC}$ (MHz/Torr)	0,240	0,013	5,42
$\Gamma_2/\Gamma_0$	0,610	0,040	6,56
$\Delta_2/\Delta_0$	0,008	0,003	37,50
$\eta$	0,0008	0,04	
→ S ( $10^{-25}$ cm/molecule)	3,475	0,004	0,12

Measured linestrength by A. Kassi and J. Campargue

$$S = 3,577 \times 10^{-25} \text{ cm/molecule} \longrightarrow \text{Relative difference 1.4\%}$$

Theoretical calculations

*K. Pachucki and J. Komasa. Phys. Rev. A78 (2008): 052503.*

$$S = 3,526 \times 10^{-25} \text{ cm/molecule} \longrightarrow \text{Relative difference 3\%}$$

# Uncertainty budget

Source	Type A (kHz)	Type B (kHz)
Reproducibility	94	
Line shape model		54
Frequency calibration		5
Detector non-linearity		Negligible
Temperature uncertainty and drift		7
Hyperfine structure effects		Negligible
AC-Stark shift		Negligible
<b>Total uncertainty ~109 kHz</b>		

# R(1) line center frequency: current status

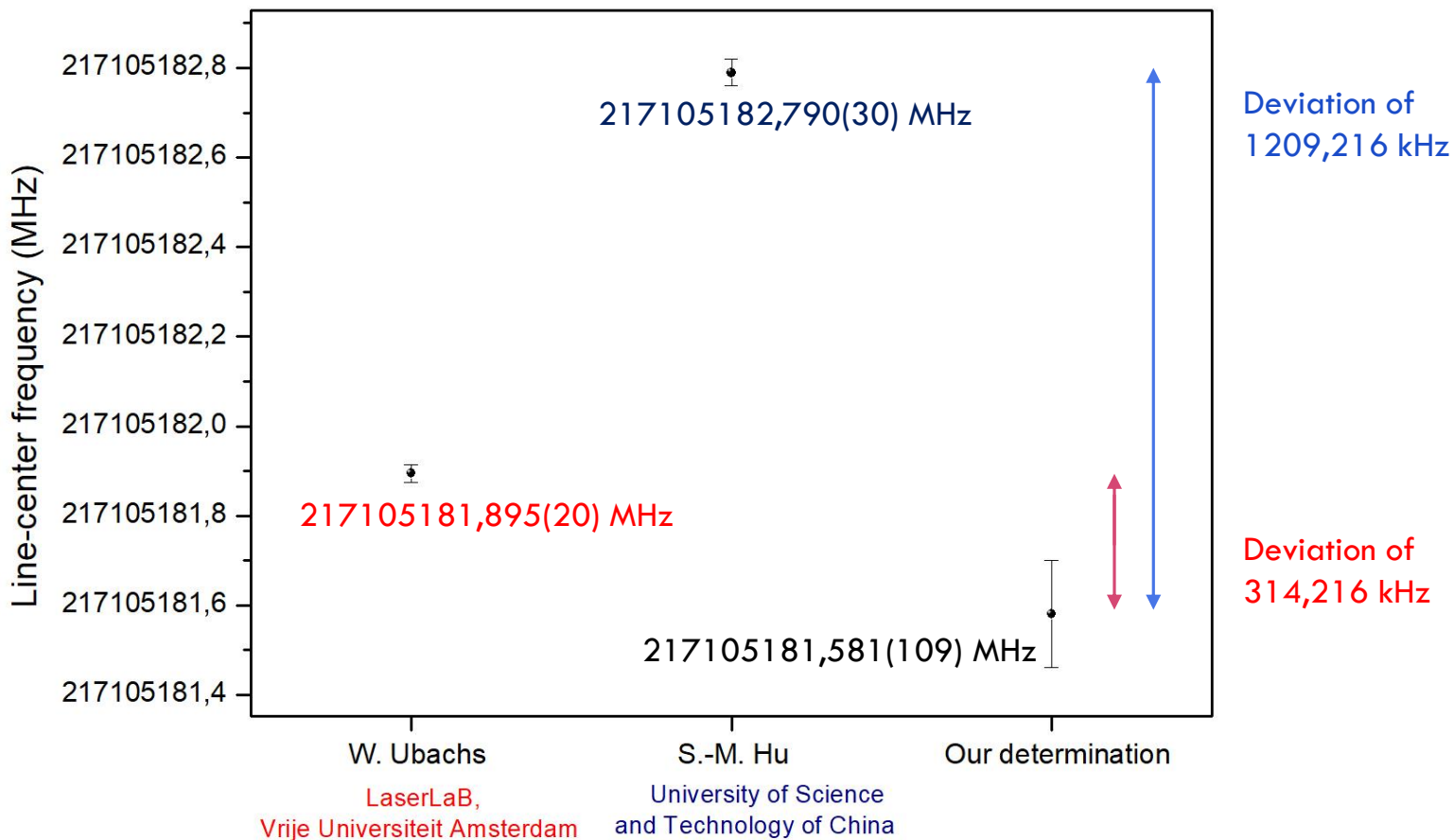

Agreement with the theoretical value **217105180(6) MHz** of Pachucki and Komasa

# Summary

- Development of the FS-CRDS set-up;
- Detection of the R(1) line of the HD spectrum;
- Implementation of a very refined and reliable line shape model;
- Highly-accurate measurement of the line-center frequency;
- Assessment of reproducibility levels;
- Overall uncertainty of 109 kHz;
- Agreement with the theoretical value.

## ... and Outlooks

- Further measurements of the HD first overtone band absolute frequency lines;
- Reproducibility improvement.



The comparison of the experimental and theoretical energy levels will set constraints on the hypotheses beyond the Standard Model.

**Thank you for your attention!!**

